

Metal air supply valve

KNT-RML



Description

KNT air supply valves can be installed in the ceiling, on the wall or directly in the mouth of a ventilation duct using a dedicated RML mounting frame. They allow smooth adjustment of the air exhaust flow rate by rotating the disk closure in the centre. The air flow rate depends on the opening ratio, i.e. the distance between the disk closure distance and the round bezel, and it is set with a locknut. The carefully designed geometry of the valve guarantees low noise level as well as quick and easy installation. On the inside of the KNT valve, there is a deflector to control the air flow angle.



The standard air supply valves are supplied with a mounting frame (product code: KNT-RML).

Available materials — Product code examples

KNT-RML-...- galvanized steel sheet, powder-coated finish
high-gloss RAL 9016

Product code example

Product code: **KNT-RML - aaa**

type _____
Ød _____

Technical specifications

Sound pressure level, LA (dB(A))

Dimensions [mm]	Mean frequency [Hz]						
	125	250	500	1000	2000	4000	8000
100	-6	-2	-3	-5	-8	-9	-15
125	0	1	-1	-5	-15	-21	-33
160	3	2	-1	-6	-15	-23	-36
tolerance	3	2	2	2	2	2	3

Dimensions

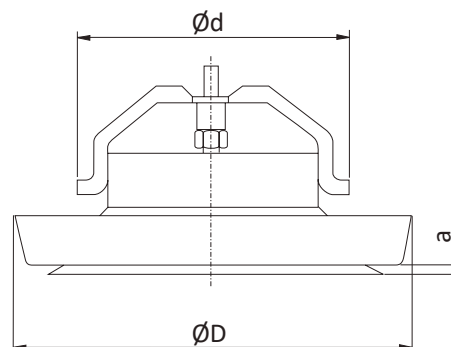

Ød [mm]	ØD [mm]	Weight [kg]
100	135	0.28
125	165	0.44
160	205	0.62

Measure

DN	s [mm]					
		4	6	9	12	15
KNT-100	k	1,2	1,7	1,8	2,6	3,3
KNT-125	k	2,0	3,0	3,4	4,3	4,6
KNT-160	k	2,4	2,9	5,3	6,1	7,1

$$q = k \cdot \sqrt{dp}$$

q - air flow rate [l/s].

k - coefficient from the table [-].

dp - value of relative static pressure in the ventilation duct before the diffuser [Pa].

s - front plate position

Sound insulation level (dB)

Dimensions [mm]	Mean frequency [Hz]							
	63	125	250	500	1000	2000	4000	8000
100	22	18	13	11	9	8	7	8
125	20	16	11	9	9	7	6	5
160	18	14	10	9	9	7	6	6
tolerance	6	3	2	2	2	2	2	3

Metal air supply valve KNT-RML

Technical specifications

The following performance parameters: volumetric flow rate, q (l/s or m^3/h), total pressure drop, P_t (Pa), and sound pressure level, L_A (dB(A)), can be read from the chart.

Pressure drop, P_t
The charts show the total pressure drop, P_t (Pa).

Sound pressure level, L_A
The charts show the sound pressure level, L_A (dB(A)). The noise level is shown for the sound insulation level at 4 dB indoors, which corresponds to sound insulation performance in the reverberation zone at the room absorption level for 10 m^2 according to SABINE's formula.

Selection charts for air valves w/o deflectors

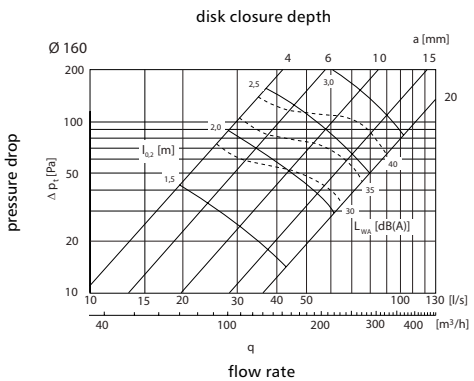
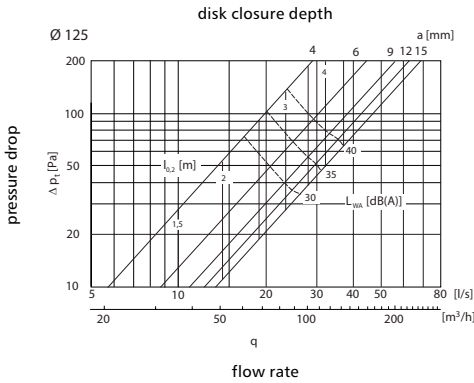
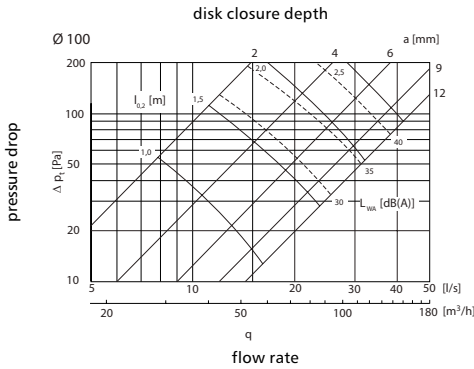

Selection charts for air valves with deflectors

